

Digital Logic.

Ways of controlling digital circuits.

Computer Science Department
Texas A&M University Commerce
Modified by Dr. Nikolay Metodiev Sirakov

Computers use the binary number system

Only two numbers - A Zero & A One

A Voltage represents a number

+5 Volts = 1 0 Volts = 0

Digital logic is basically nothing more than a set of switches we use to control the flow of electricity.

AND Gate



Truth Table

A	B	F
0	0	0
0	1	0
1	0	0
1	1	1

OR Gate

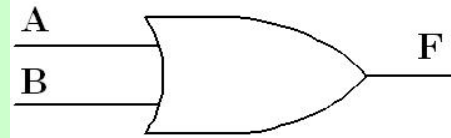

Truth Table

A	B	F
0	0	0
0	1	1
1	0	1
1	1	1

NOT Gate

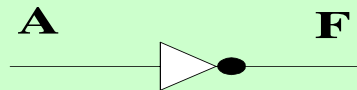

Truth Table

A	F
0	1
1	0

Other Logic Gates

All other Digital Logic Gates are a combination of the basic four gates.

Two Input Gates

We will learn here:

- How to find the truth table of a digital circuit;**
- How to analyze the scheme in order to simplify our work;**
- How to code Hex Decimal numbers.**

NAND Gate

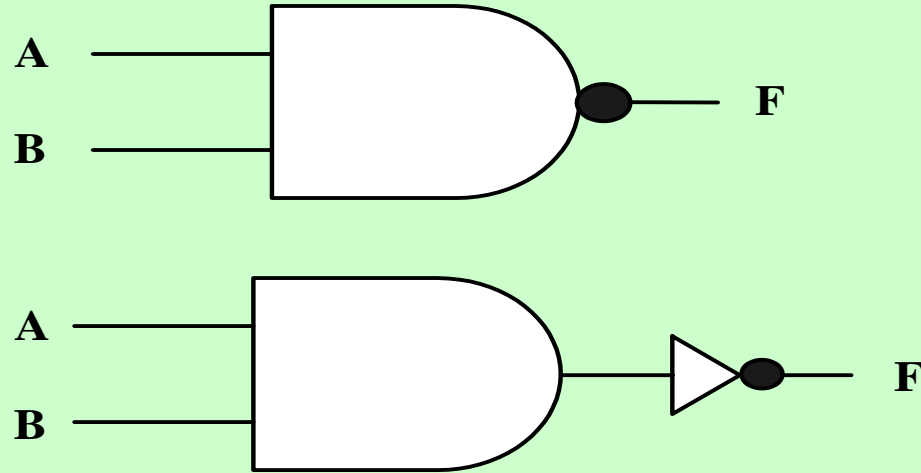

Truth Table

AND Gate

A	B	F
0	0	0
0	1	0
1	0	0
1	1	1

Truth Table

NAND Gate

A	B	F
0	0	1
0	1	1
1	0	1
1	1	0

NOR Gate

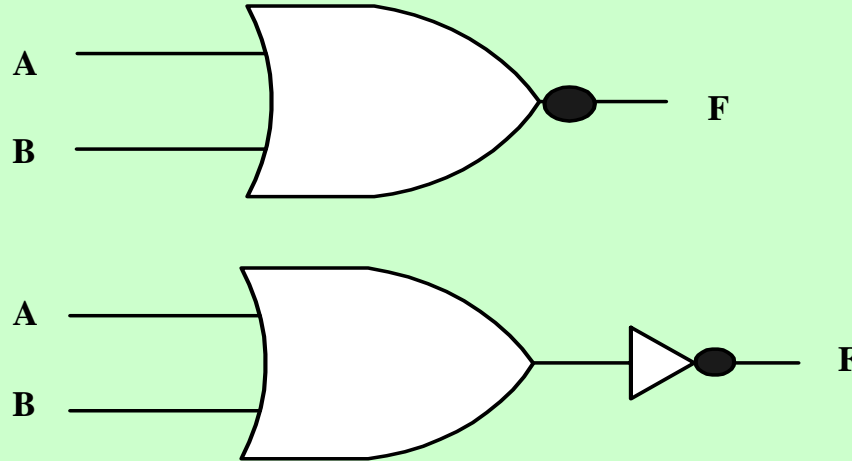

Truth Table

OR Gate

A	B	F
0	0	0
0	1	1
1	0	1
1	1	1

Truth Table

NOR Gate

A	B	F
0	0	1
0	1	0
1	0	0
1	1	0

XOR (Exclusive OR)

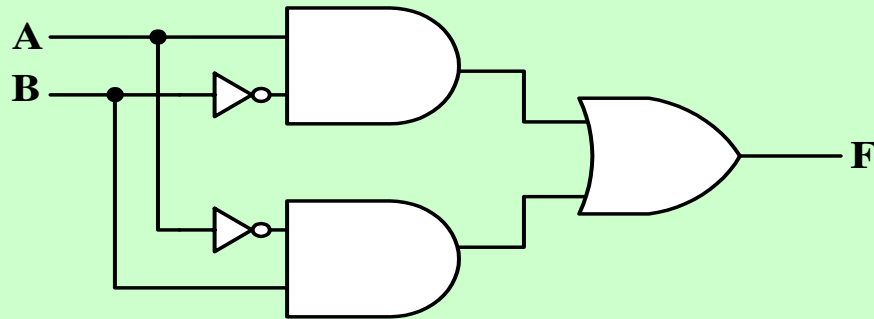
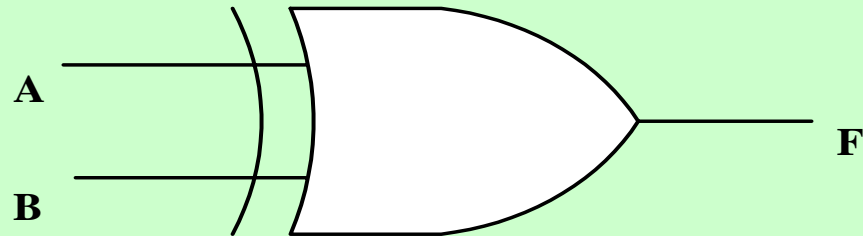

Truth Table

A	B	F
0	0	
0	1	
1	0	
1	1	

Truth Table for XOR Gate

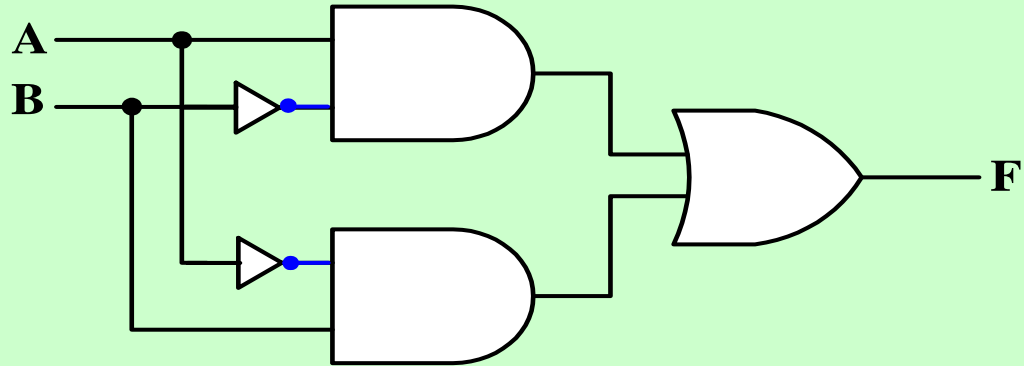

Truth Table

A	B	F
0	0	0
0	1	
1	0	
1	1	

Truth Table for XOR Gate

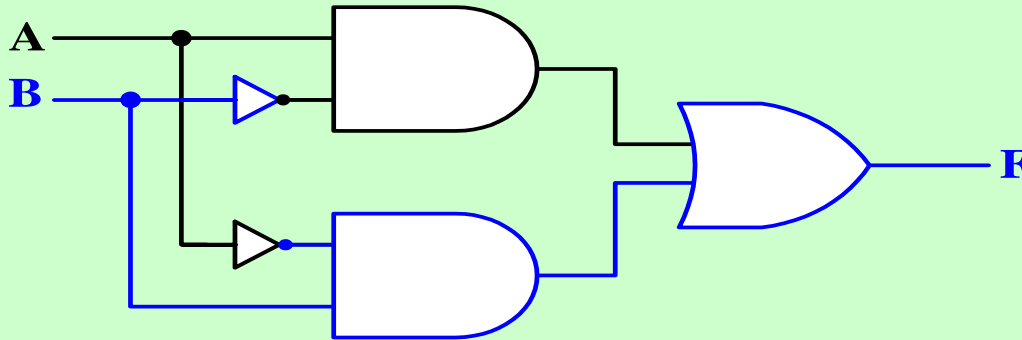

Truth Table

A	B	F
0	0	0
0	1	1
1	0	
1	1	

Truth Table for XOR Gate

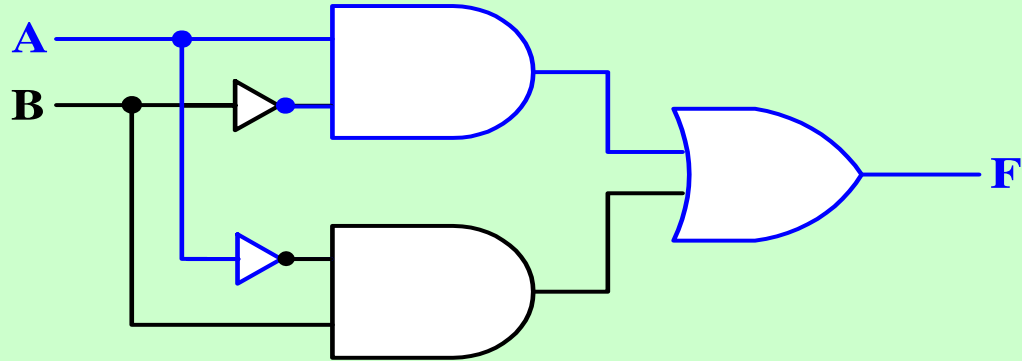

Truth Table

A	B	F
0	0	0
0	1	1
1	0	1
1	1	0

Truth Table for XOR Gate

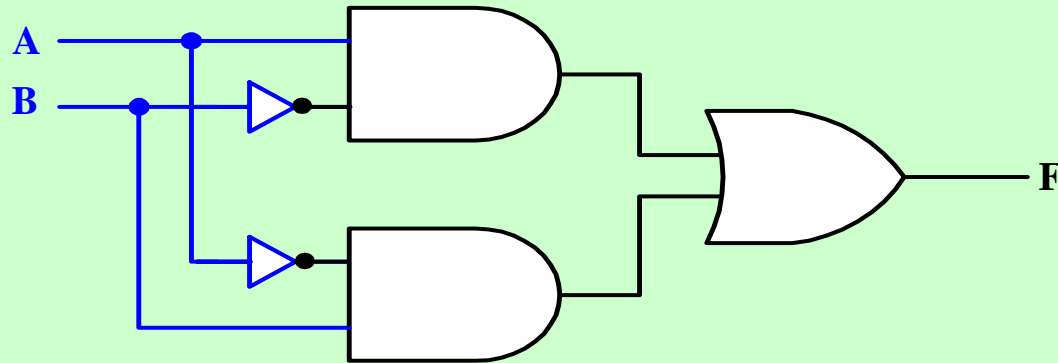

Truth Table

A	B	F
0	0	0
0	1	1
1	0	1
1	1	0

Other Gates with NOT Gates

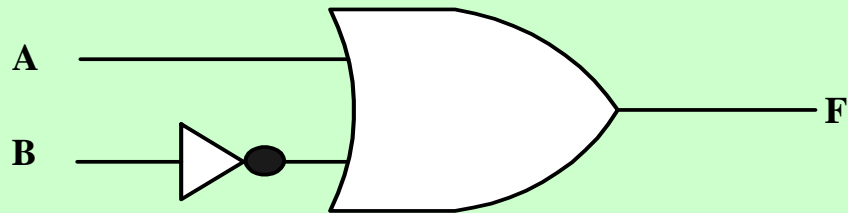
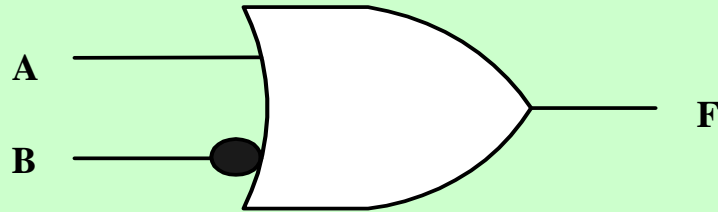

Truth Table Truth Table

OR Gate

A	B	F
0	0	0
0	1	1
1	0	1
1	1	1

... Gate

A	B	F
0	0	1
0	1	0
1	0	1
1	1	1

Multi-Input Gates

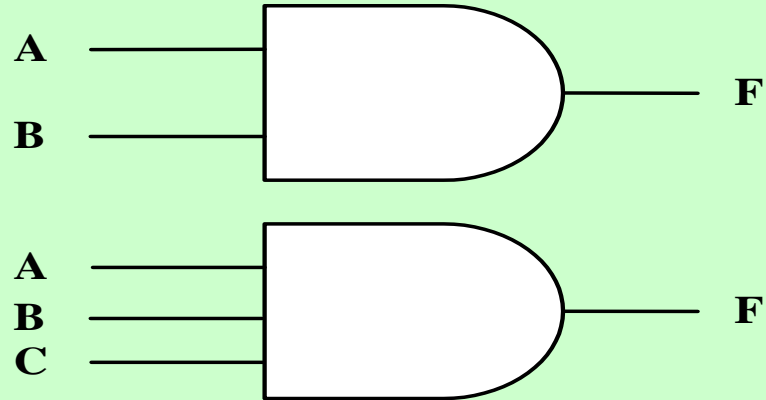

Truth Table

3 Input AND Gate

A	B	C	F
0	0	0	0
0	0	1	0
0	1	0	0
0	1	1	0
1	0	0	0
1	0	1	0
1	1	0	0
1	1	1	1

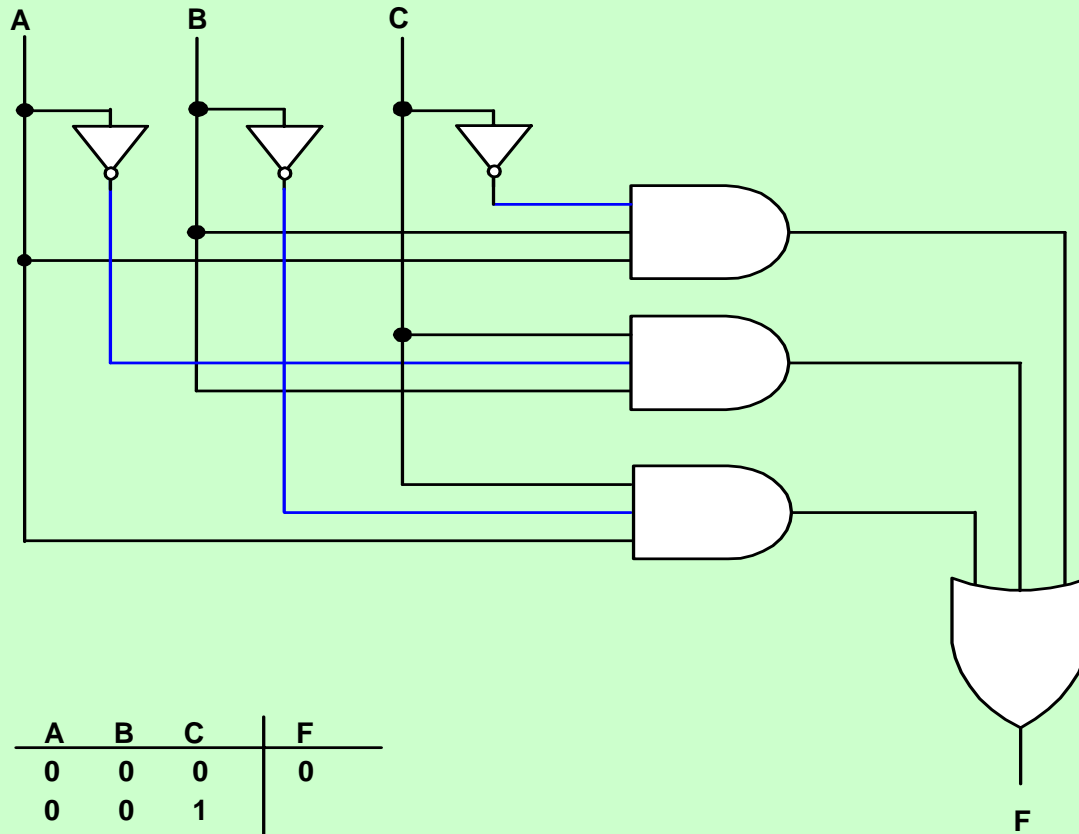

A	B	C	F
0	0	0	0
0	0	1	
0	1	0	
0	1	1	
1	0	0	
1	0	1	
1	1	0	
1	1	1	

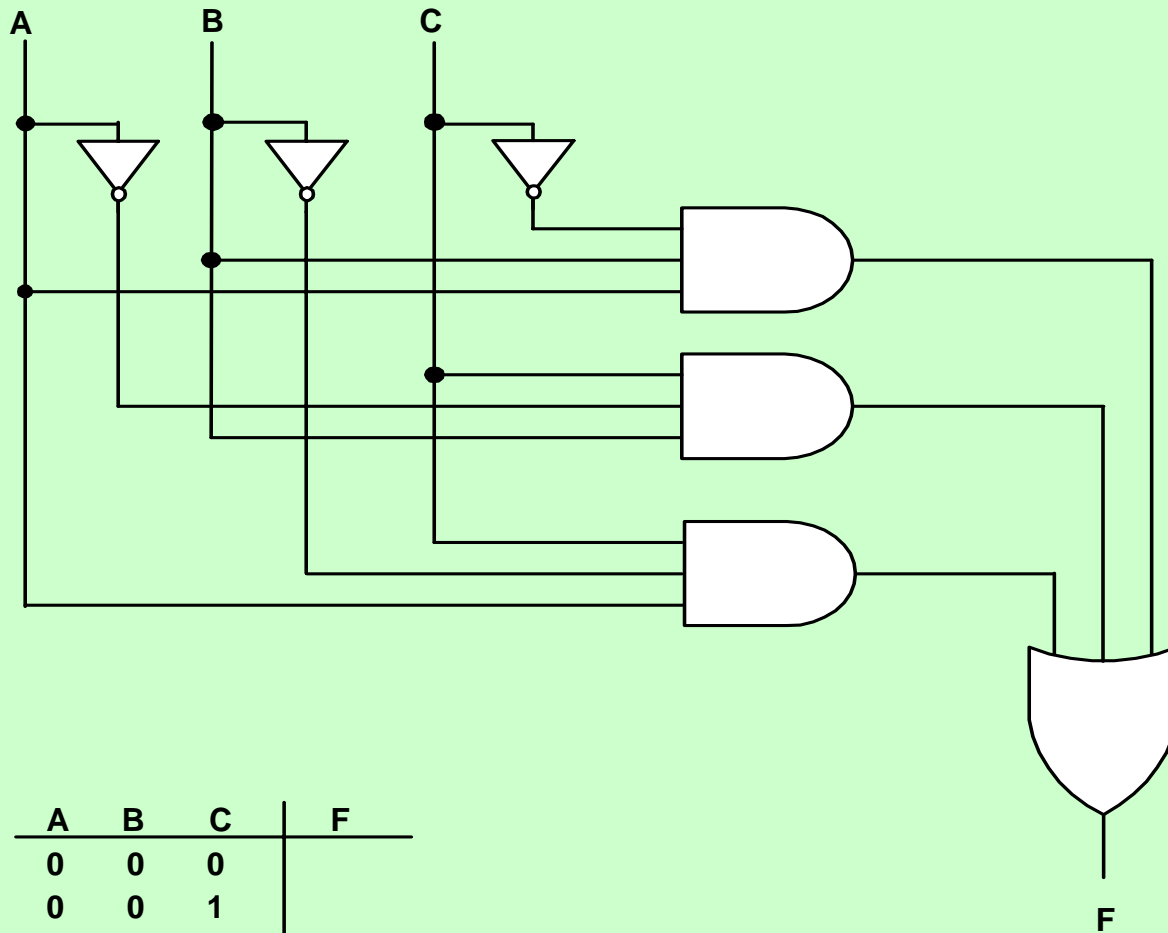

A	B	C	F
0	0	0	
0	0	1	
0	1	0	
0	1	1	
1	0	0	
1	0	1	
1	1	0	
1	1	1	

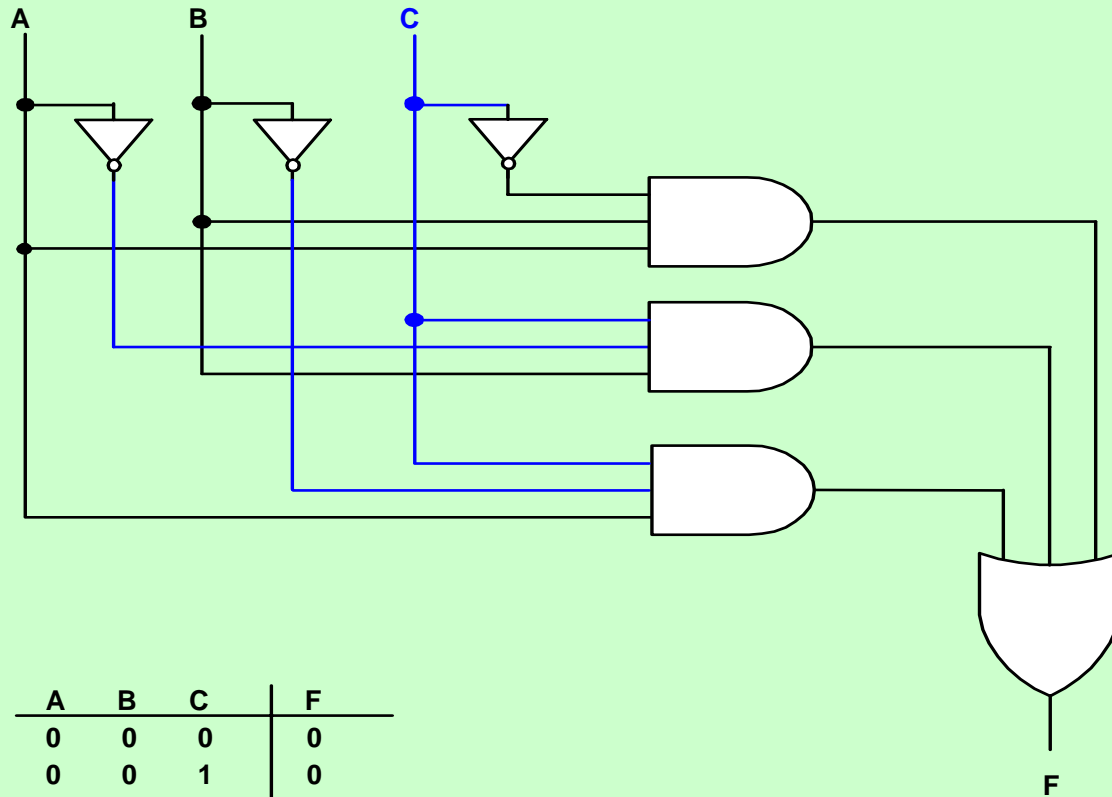

A	B	C	F
0	0	0	0
0	0	1	0
0	1	0	
0	1	1	
1	0	0	
1	0	1	
1	1	0	
1	1	1	

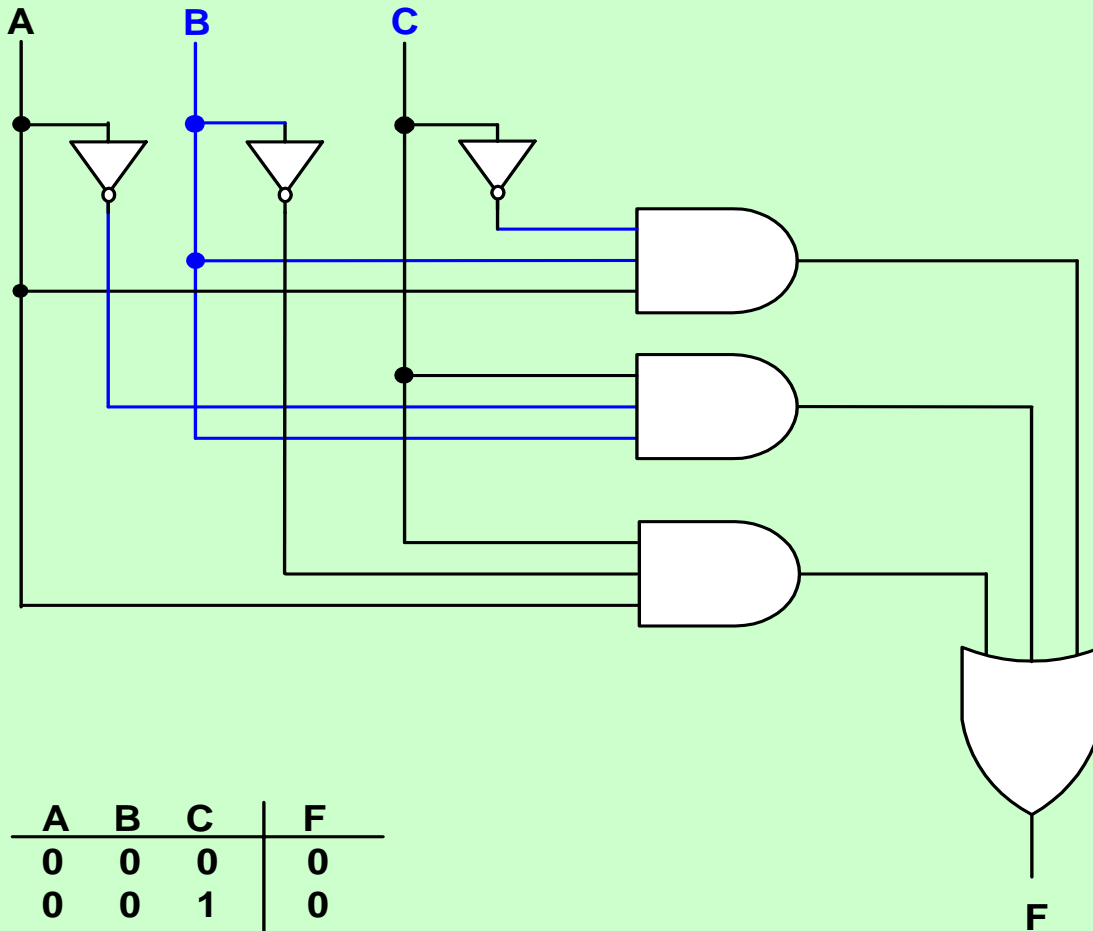

A	B	C	F
0	0	0	0
0	0	1	0
0	1	0	0
0	1	1	
1	0	0	
1	0	1	
1	1	0	
1	1	1	

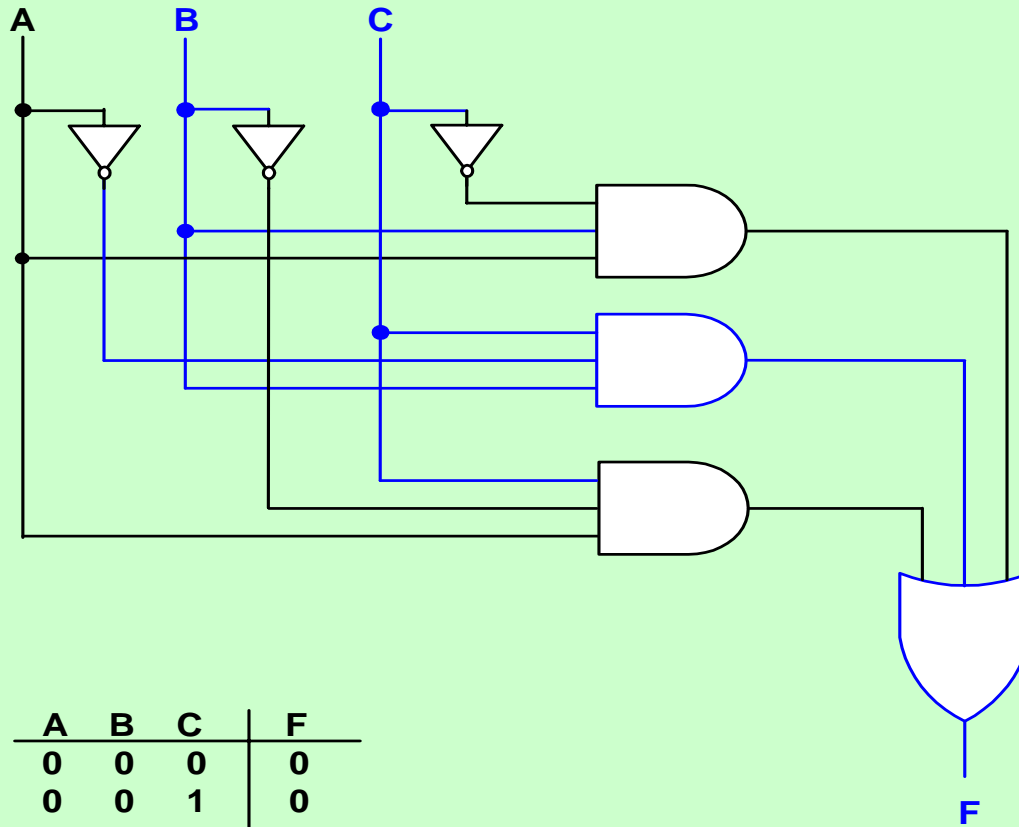

A	B	C	F
0	0	0	0
0	0	1	0
0	1	0	0
0	1	1	1
1	0	0	
1	0	1	
1	1	0	
1	1	1	

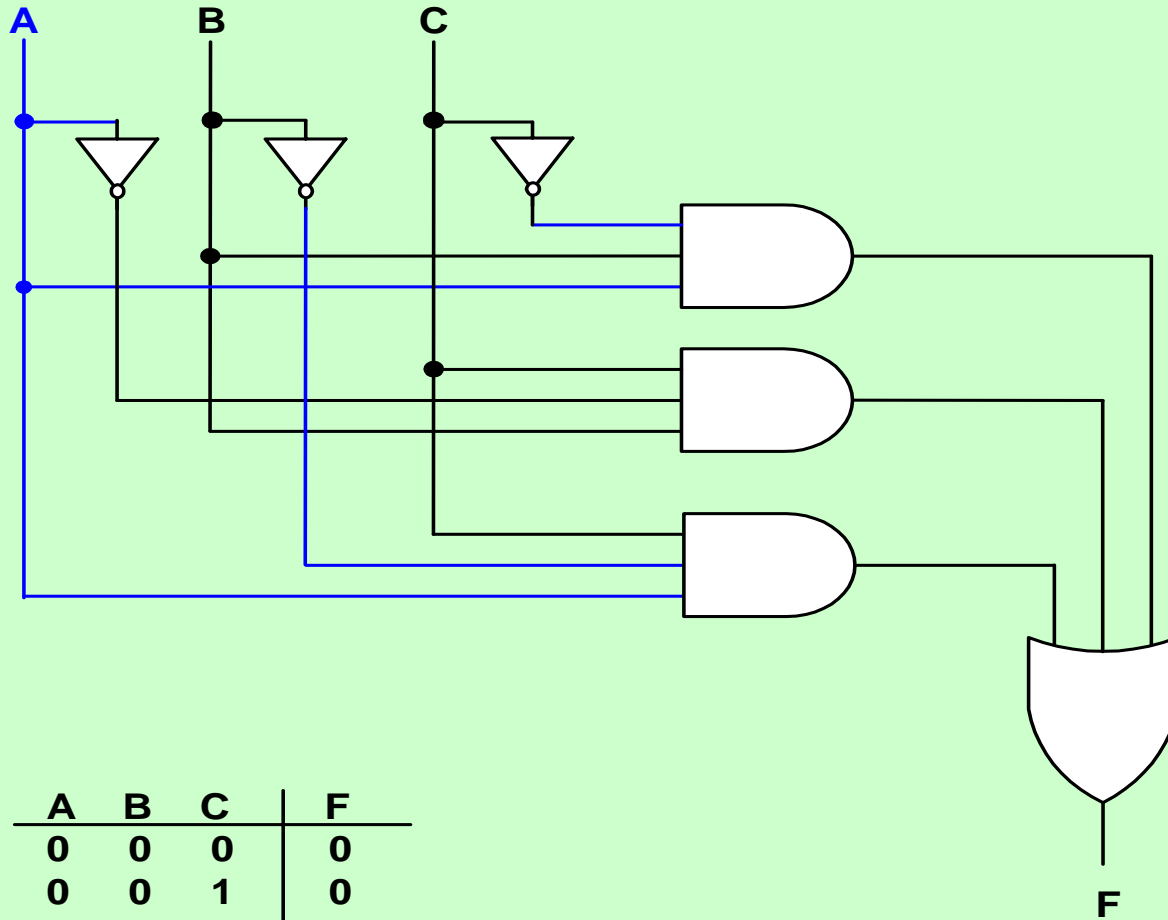

A	B	C	F
0	0	0	0
0	0	1	0
0	1	0	0
0	1	1	1
1	0	0	0
1	0	1	0
1	1	0	0
1	1	1	0

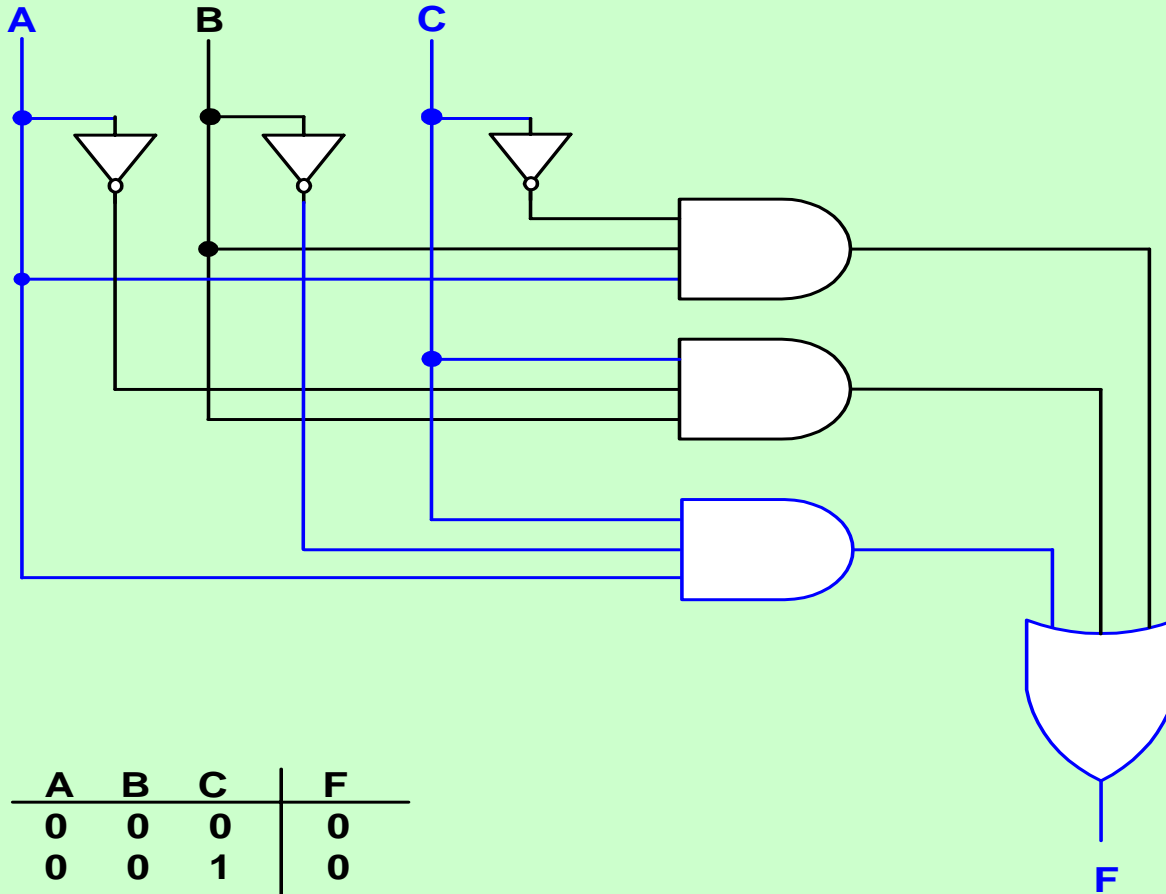

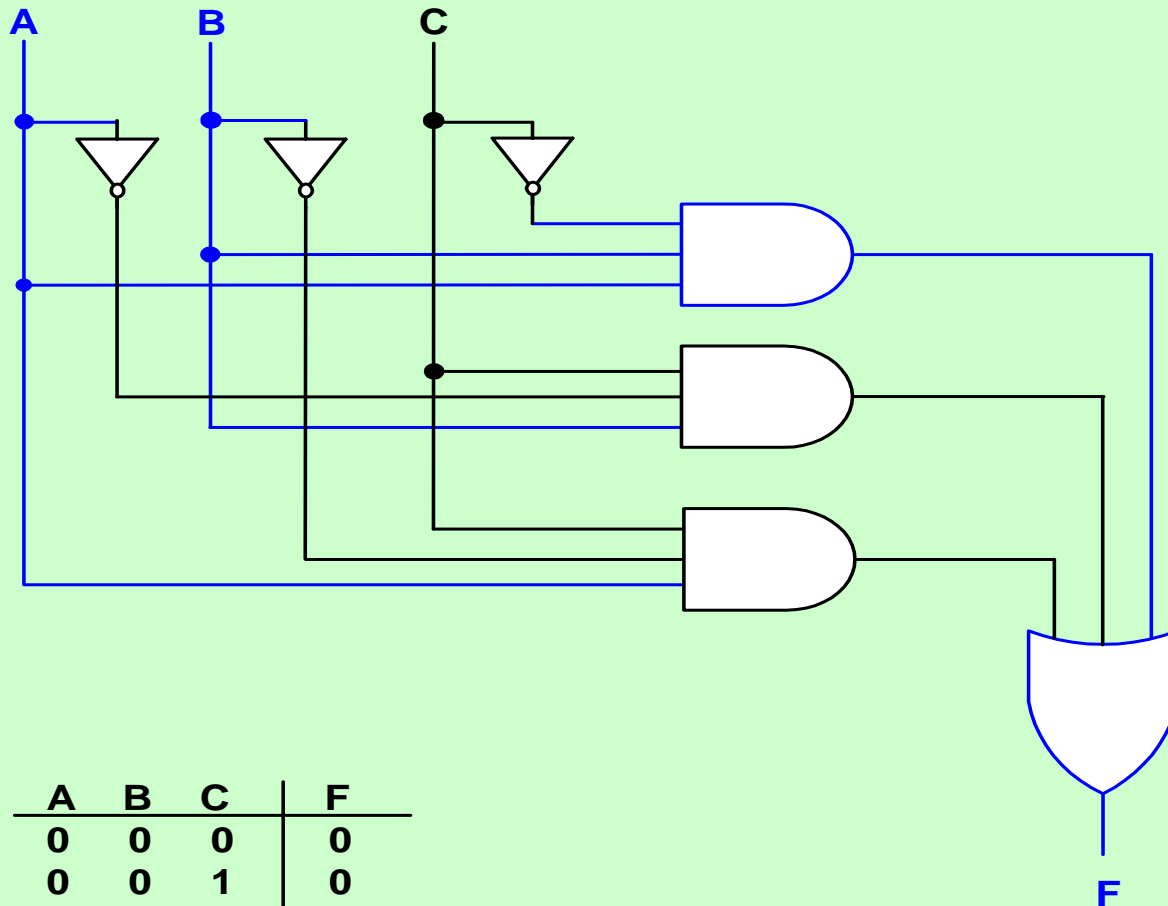

A	B	C	F
0	0	0	0
0	0	1	0
0	1	0	0
0	1	1	1
1	0	0	0
1	0	1	1
1	1	0	1
1	1	1	1

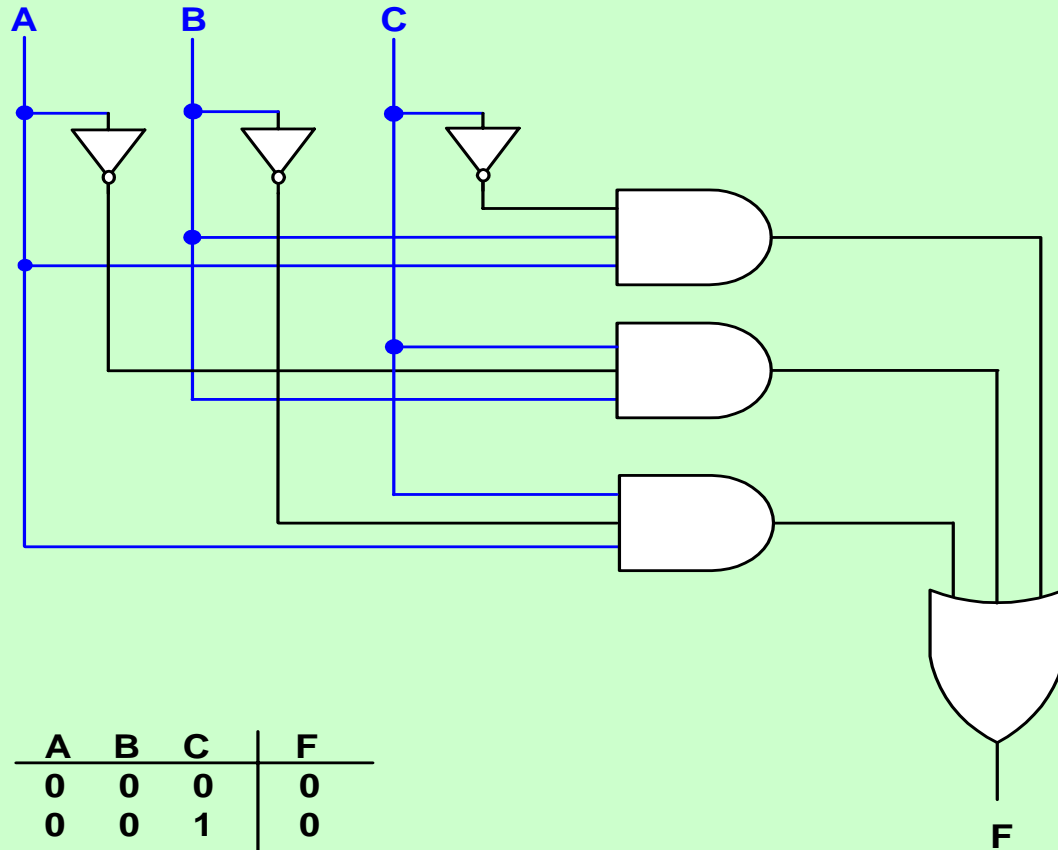

A	B	C	F
0	0	0	0
0	0	1	0
0	1	0	0
0	1	1	1
1	0	0	0
1	0	1	1
1	1	0	1
1	1	1	0

Two to Four Decode

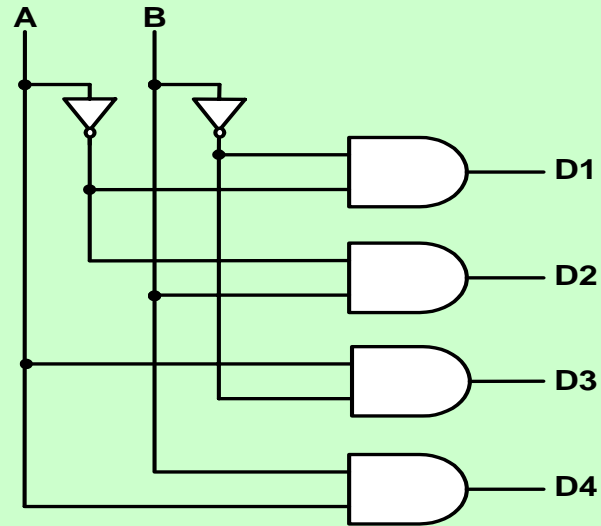

A	B	D1	D2	D3	D4
0	0				
0	1				
1	0				
1	1				

Two to Four Decode

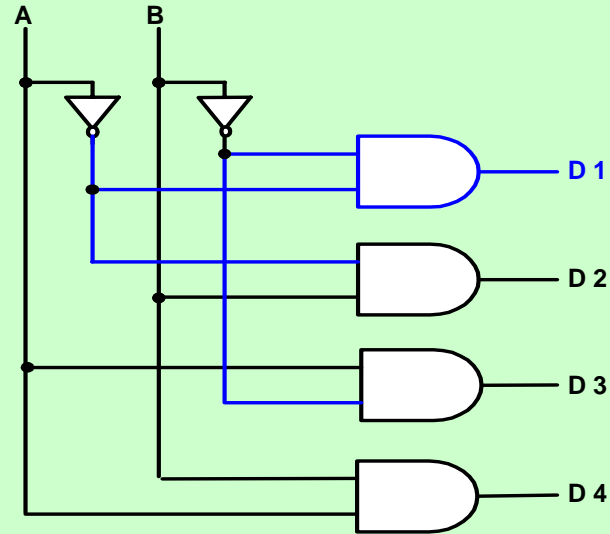

A	B	D 1	D 2	D 3	D 4
0	0	1	0	0	0
0	1	0	1	0	0
1	0	0	0	1	0
1	1	0	0	0	1

Two to Four Decode

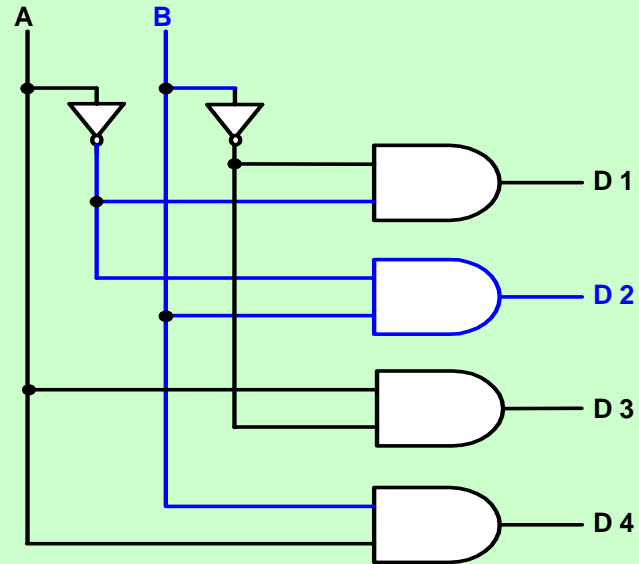

A	B	D 1	D 2	D 3	D 4
0	0	1	0	0	0
0	1	0	1	0	0
1	0	0	0	1	0
1	1	0	0	0	1

Two to Four Decode

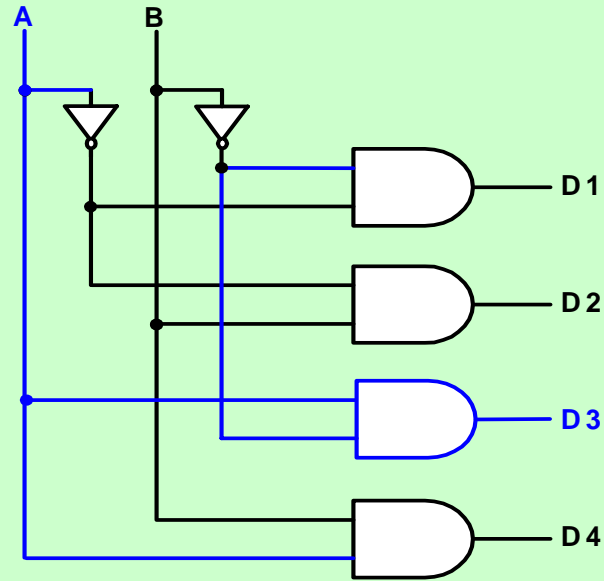

A	B	D 1	D 2	D 3	D 4
0	0	1	0	0	0
0	1	0	1	0	0
1	0	0	0	1	0
1	1	0	0	0	1

Two to Four Decode

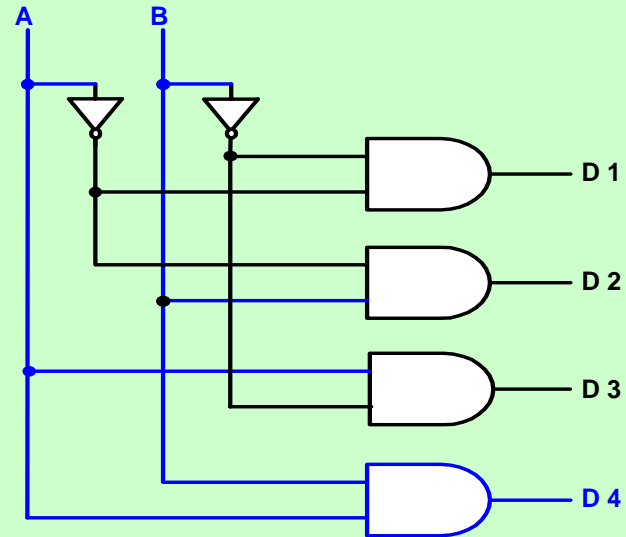

A	B	D 1	D 2	D 3	D 4
0	0	1	0	0	0
0	1	0	1	0	0
1	0	0	0	1	0
1	1	0	0	0	1

4 to 16 Decoder - Truth Table

A 3	A 2	A 1	A 0	Value	Line
0	0	0	0	0	0000
0	0	0	1	1	0001
0	0	1	0	2	0010
0	0	1	1	3	0011
0	1	0	0	4	0100
0	1	0	1	5	0101
0	1	1	0	6	0110
0	1	1	1	7	0111
1	0	0	0	8	1000
1	0	0	1	9	1001
1	0	1	0	10	1010
1	0	1	1	11	1011
1	1	0	0	12	1100
1	1	0	1	13	1101
1	1	1	0	14	1110
1	1	1	1	15	1111

4 to 16 Decoder

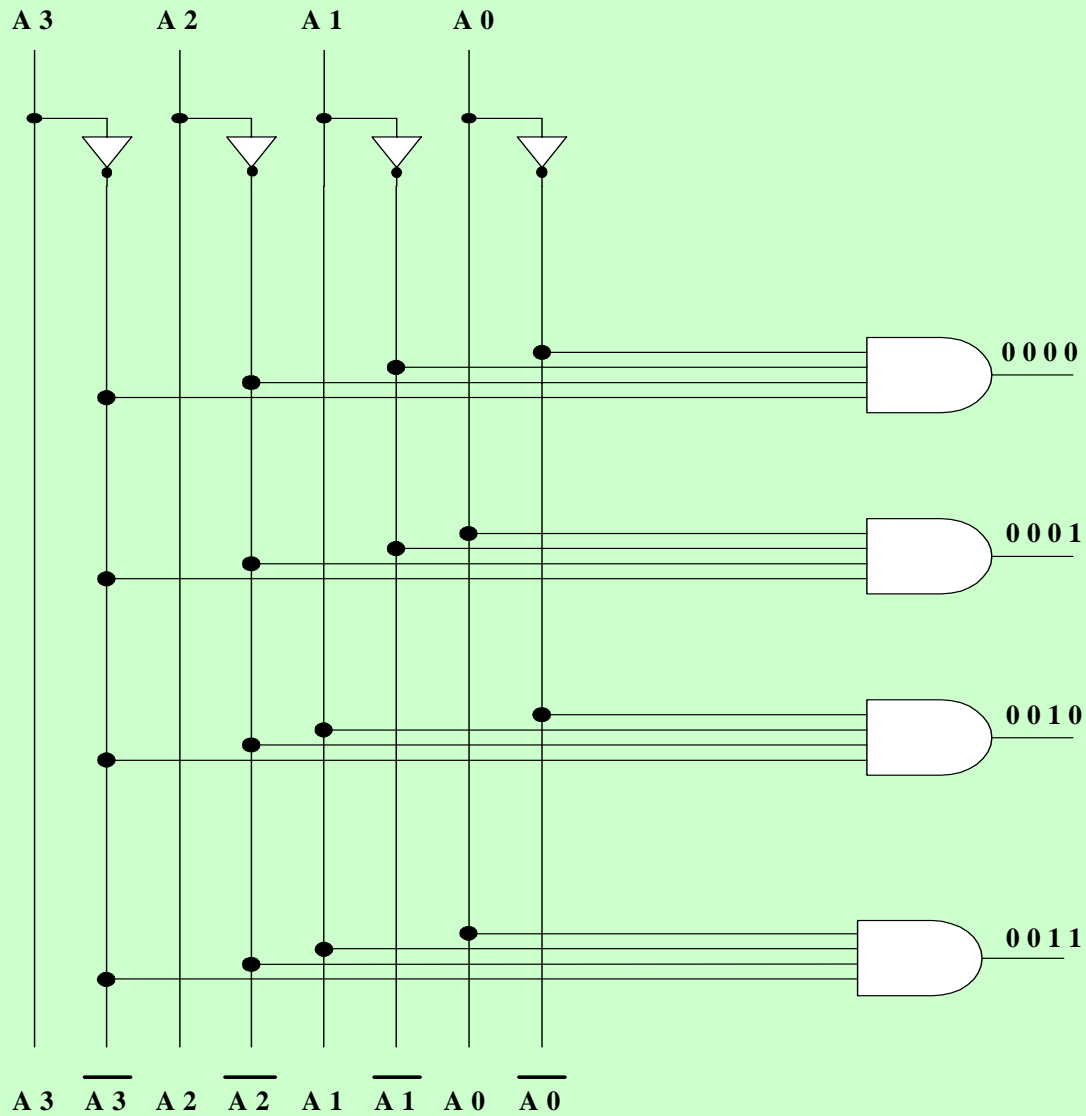

4 to 16 Decoder - Page 2

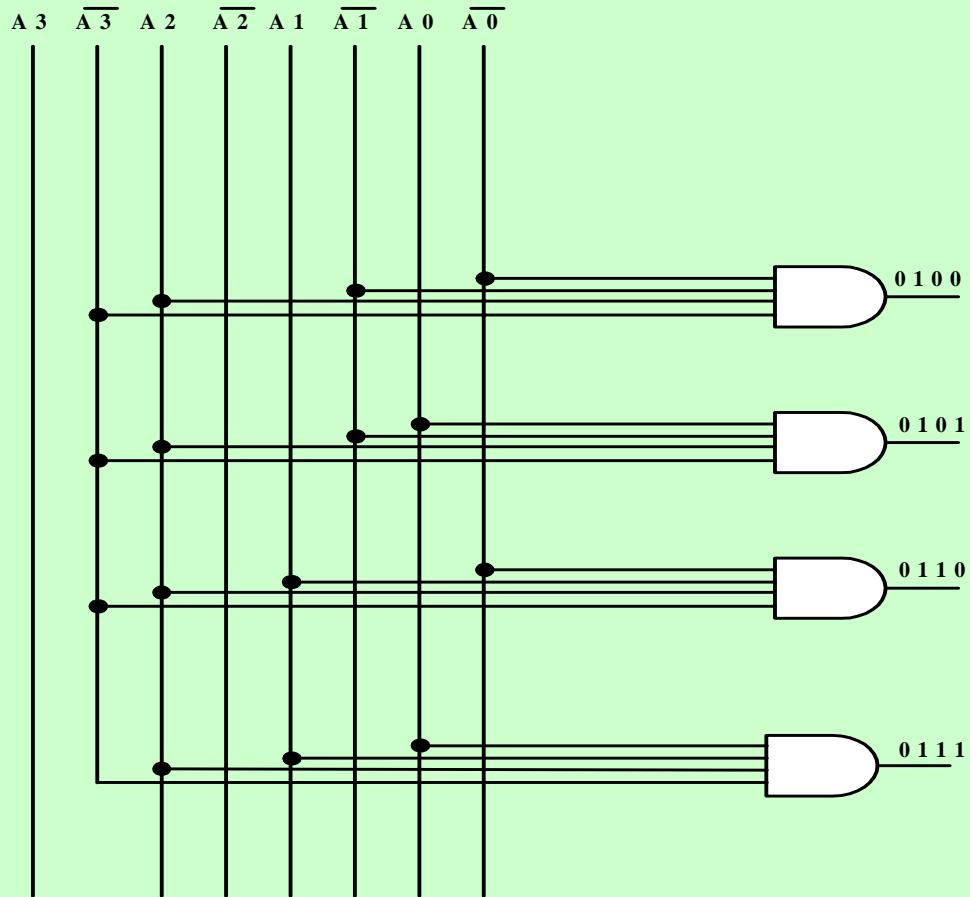

4 to 16 Decoder - Page 3

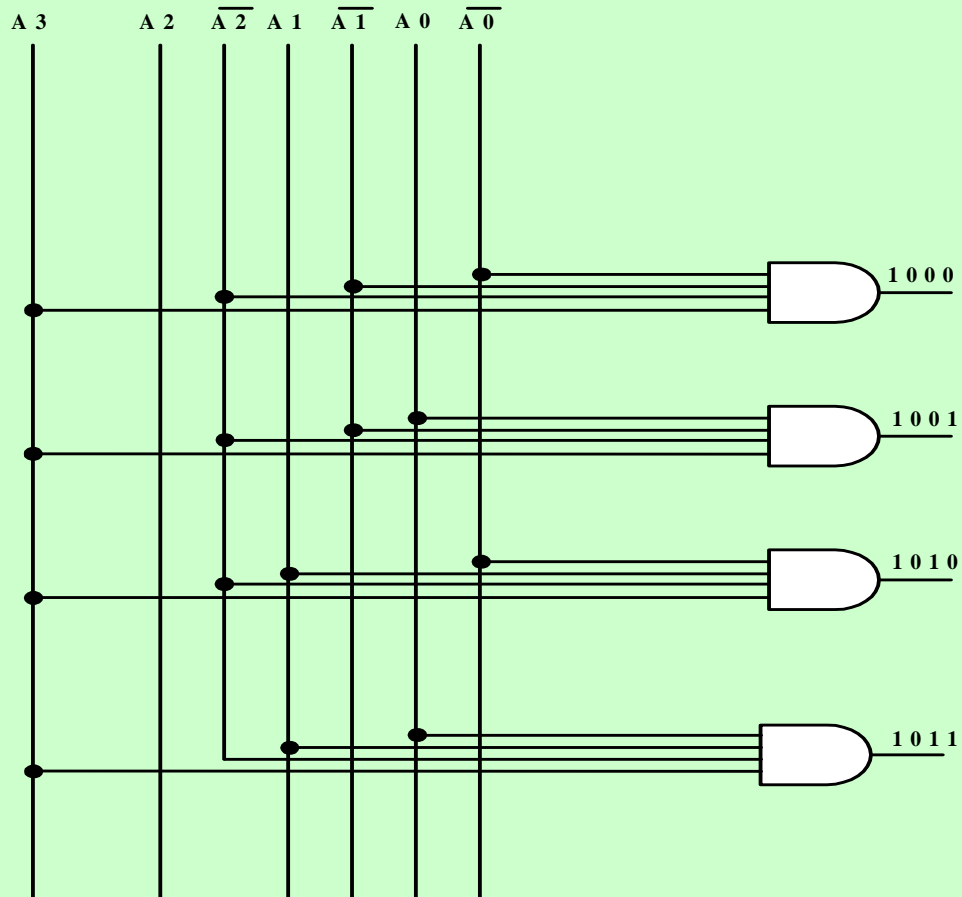

4 to 16 Decoder - Page 4

